

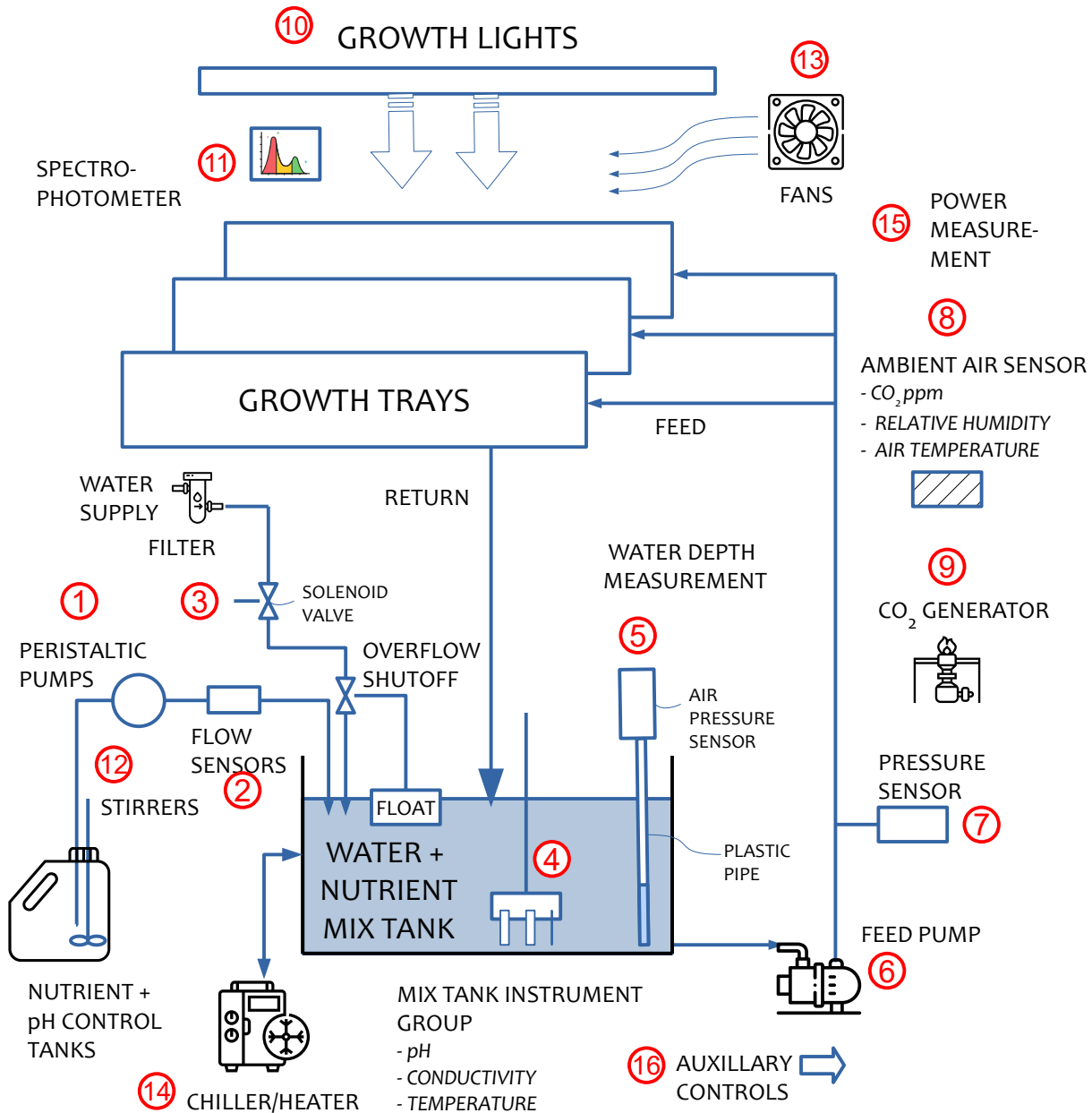

# A hydroponics monitoring and control system

## ABSTRACT

A hydroponics monitoring and control system implementation is described.



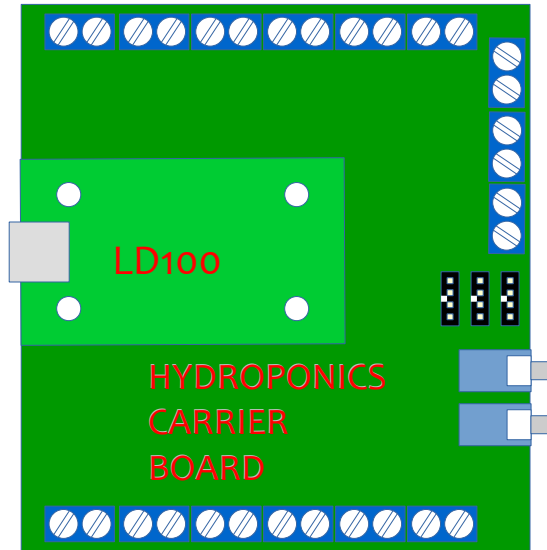

1) Peristaltic Pumps

6x12V, current TBD

low duty cycle

12) Stirrers

6x12V, current TBD

These can all run at the same time so a single control line is sufficient

2) Flow sensors

on/off switch type

They can all be Ored together since only a single peristaltic pump will run at a time

3) Solenoid Valve

24VAC, current TBD

4) Instrument group

pH, EC, temp

cAFE1, cAFE2, thermistor

5) Water depth

Utilizing laser distance ranger

6) Feed pump

110/220V on/off

Very high duty cycle, electromagnetic relays not suitable

7) Pressure sensor

Generates voltage proportional to pressure

1 ADC channel req

8) Ambient air sensor

SCD30/40/41

CO2 concentration, humidity, temperature

9) CO2 generator

110/220V on/off

10) Growth lights

4 ch PWM control

11) Spectrophotometer

optional

13) Air circulation fan

110/220V on/off

14) heater/chiller control

110/220V on/off

15) AC power measurement

Using current coil and 1 ADC channel